

**SERIES**  
**SHOW**

CE

# Spot 1200

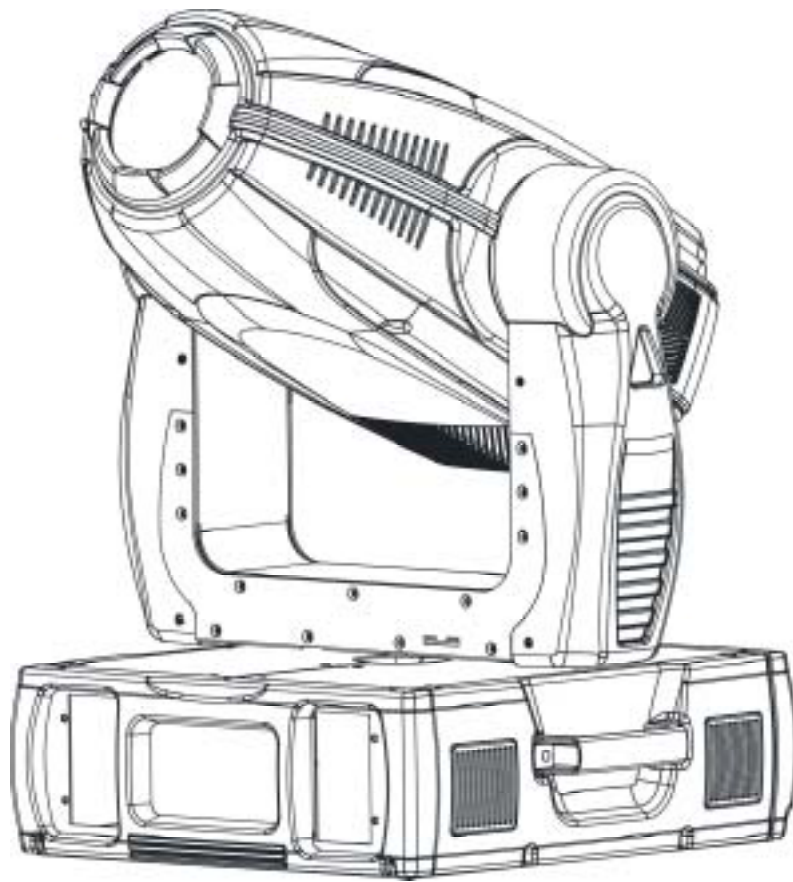

## USER MANUAL

[WWW.YAGANG.COM](http://WWW.YAGANG.COM)

 **SILVER STAR**  
*Professional Lighting*

## INTRODUCTION

This equipment is produced in accordance with CE standards and conforms to the international standard DMX512 protocol.

On receiving this product, please carefully check that there has been no damage caused in transportation and that the following parts are enclosed:

- 1 × 1200W SPOT MOVING HEAD
- 1 × SIGNAL CABLE
- 1 × USER MANUAL
- 1 × SAFETY CABLE
- 2 × CLAMPS

## IMPORTANT

**BEFORE OPERATION PLEASE CONFIRM THAT THE POWER SUPPLY STATED ON THE REAR PANEL OF THIS UNIT IS THE SAME AS THE SUPPLIED MAINS POWER IN YOUR AREA. READ THIS USER MANUAL CAREFULLY BEFORE OPERATION**

## SAFETY WARNING

- This product must be installed by a qualified professional
- All operation and maintenance must be carried out in accordance with this user manual.
- Keep this device away from any form of water or moisture at all times.
- Always disconnect the power before attempting to open the equipment housing or carrying out any maintenance.
- Avoid looking directly into the light source (especially those who suffer from epileptic fits)
- DO NOT touch the equipment casing during operation due to high temperatures of the metal and plastic housing.
- This equipment is designed for indoor use only.

## ATTENTION

- This product left our premises in perfect condition. In order for safe operation and to maintain the original condition, the user must always follow the instructions and safety warnings described in this user manual.
- The manufacturer cannot accept liability for any resulting damages caused by non-observance of this manual or any unauthorized modifications to the equipment and are not subject to warranty.
- Always make sure that the equipment is OFF before connecting the power cables.
- Always make sure that the power cable is never cut or damaged by sharp edges. It is advisable to check the state of the power cable from time to time.
- DO NOT connect this equipment to a dimmer rack.
- This device falls under Protection Class I. Therefore it is essential that the yellow/green wire must be earthed.
- If during transportation or storage the equipment has gone through drastic temperature changes, it is advisable to allow some time for the equipment to first adjust to room temperature before operation.
- Never turn on the equipment without a lamp
- Avoid shaking of strong impacts to the equipment.

- Never lift the equipment by holding it at the head or arms. Always use the handles on the base.
- DO NOT turn on the lamp at short intervals as this will reduce the lamp's life.
- The maximum ambient temperature of the housing is  $t_a=45$  . If the temperature is in excess of this the thermal switch will shut off the power.
- When transferring the product, it is advisable to use the original packaging that the unit left the factory in.

## DESCRIPTION

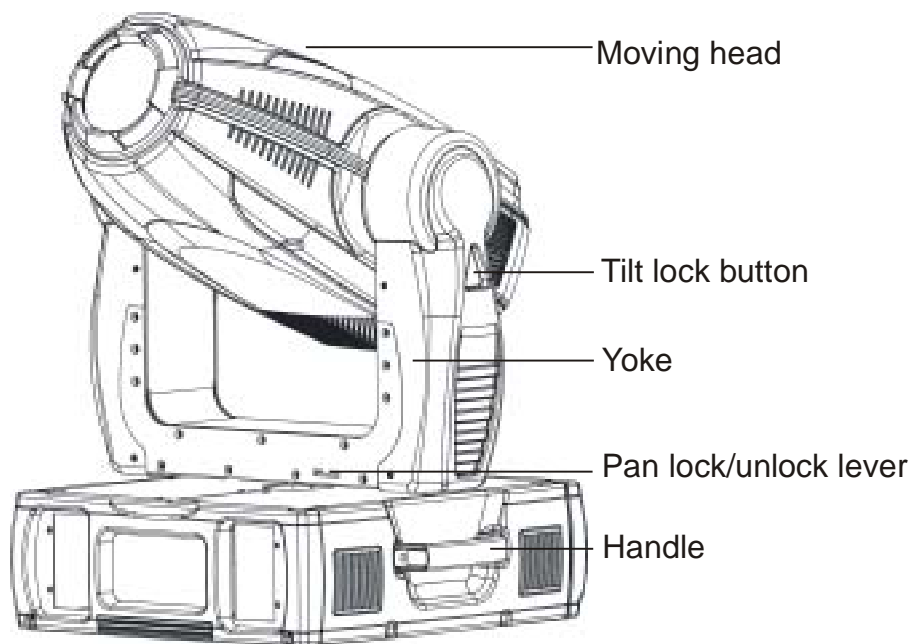

The head must be locked for transportation-the tilt lock button is pushed and the pan lock/unlock lever is in lock position. To unlock the head, press the tilt unlock button and move the pan lock/unlock lever to unlock position.

## REAR PANEL OF THE BASE

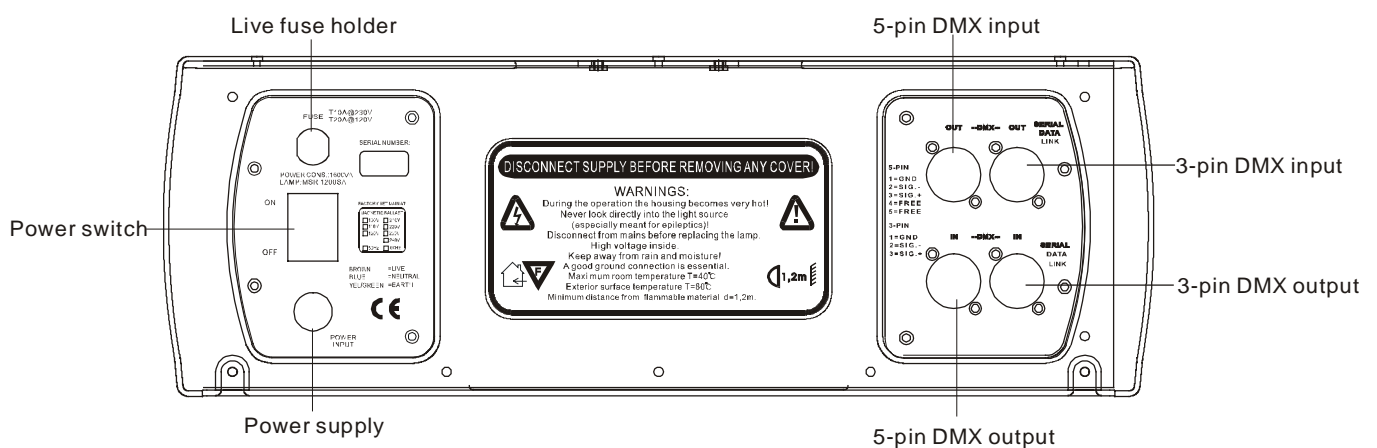

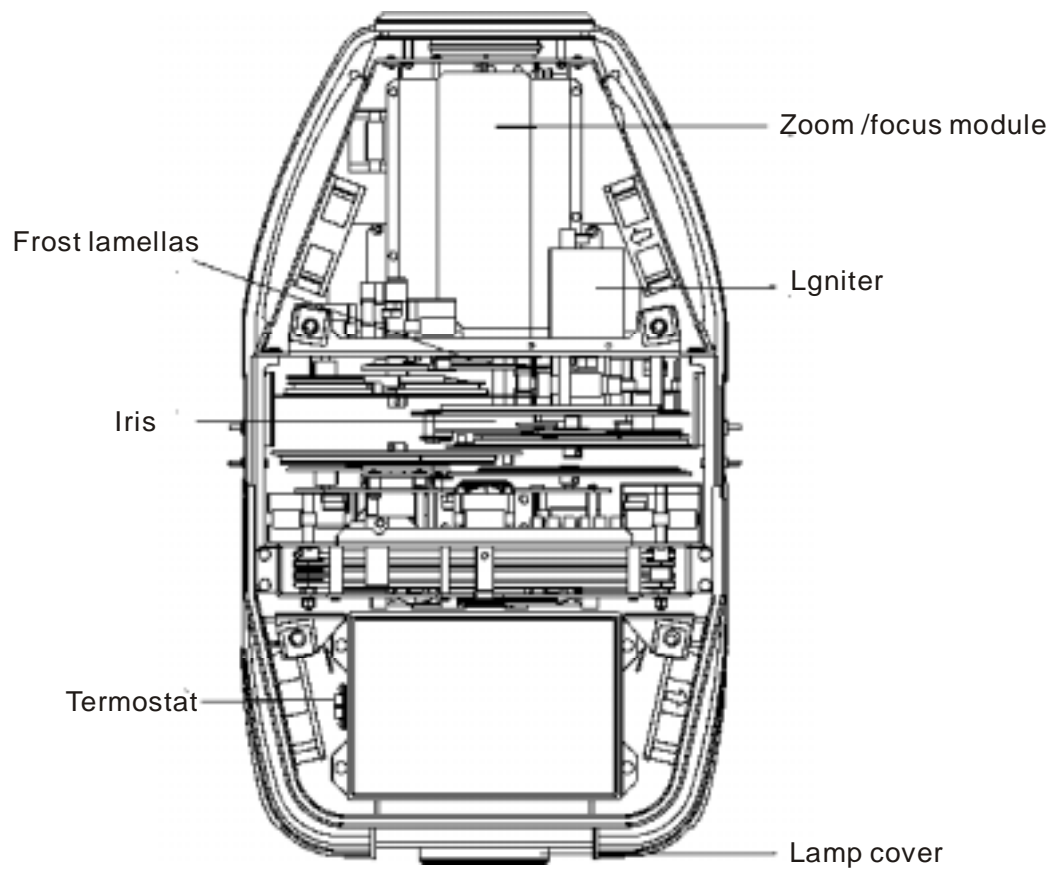
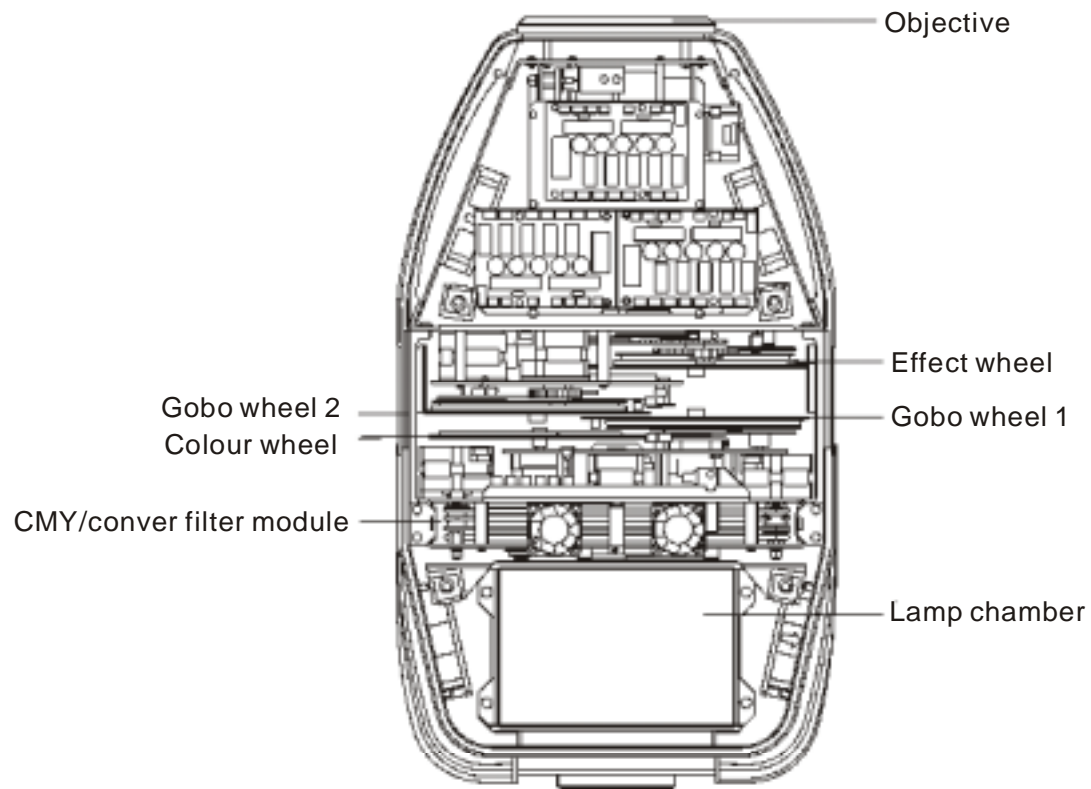

# DIMENSIONS

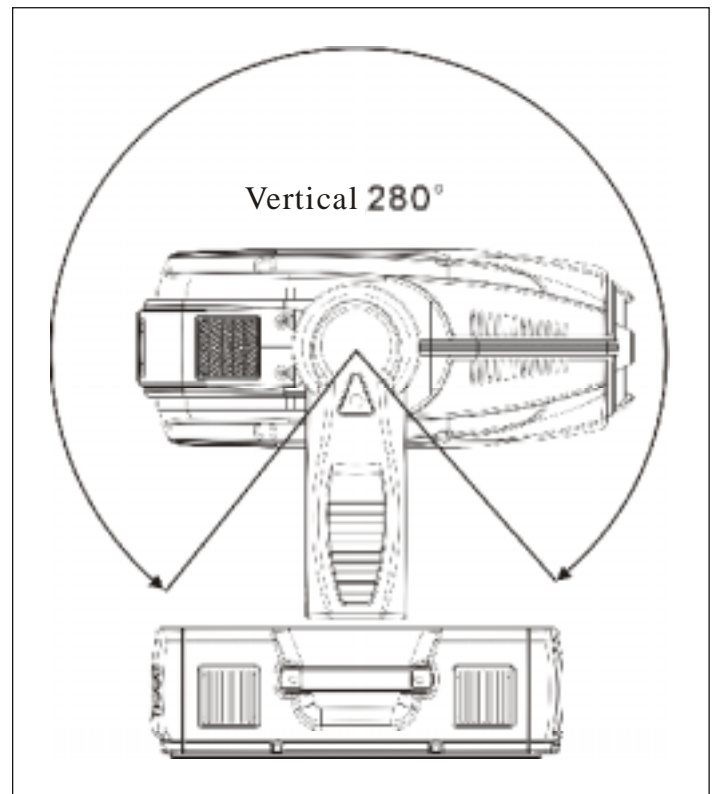
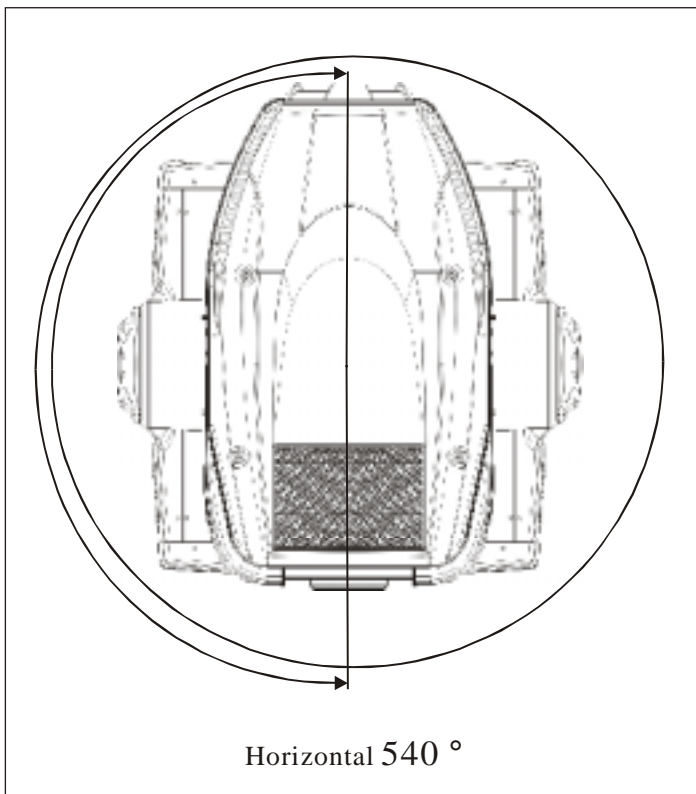
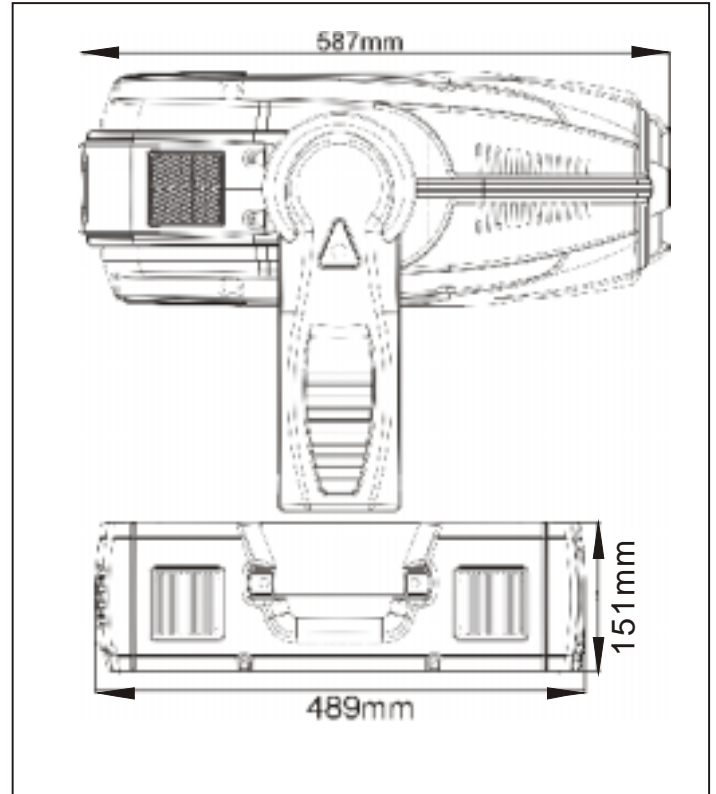
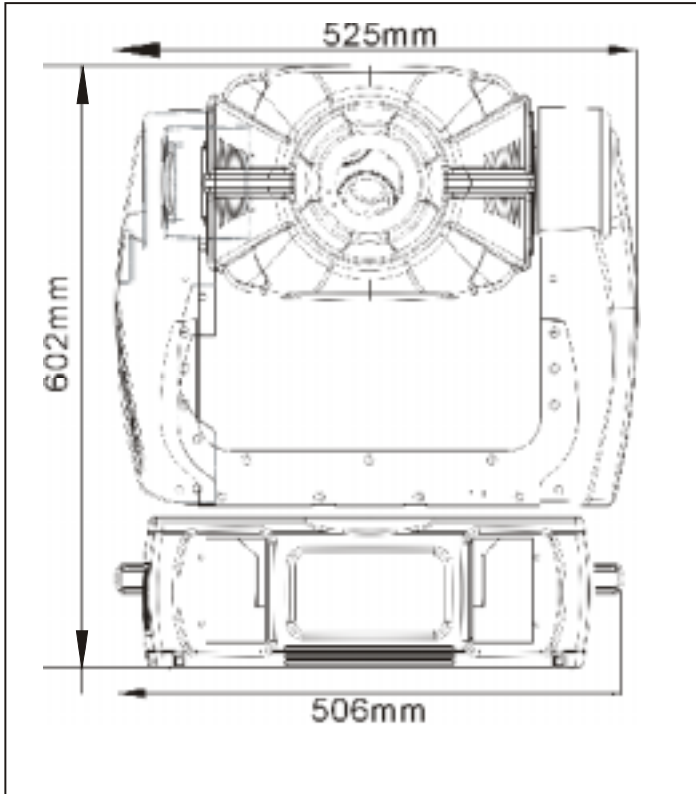

# INSTALLATION

## REPLACING LAMP

**CAUTION: ALWAYS SWITCH OFF AND UNPLUG AT THE MAINS BEFORE INSTALLING THE LAMP**

1. Disconnect the power and all the unit to cool for at least 10 minutes.
2. Loosen screws indicated **A & B** on the lamp cover at the back of the head.
3. Gently pull and remove the lamp cover and lamp holder from the head.
4. Holding the lamp by its ceramic base, carefully pull the lamp straight out of the lamp socket.
5. Holding the new lamp by its ceramic base, gently insert the lamp in to the lamp socket.
6. Reinsert the lamp cover and lamp holder and tighten screw **A & B**.

### IMPORTANT:

- Always make sure that the lamp is installed tightly into the lamp socket.
- DO NOT install a lamp other than that specified in this user manual.
- DO NOT touch the glass area of the lamp with bare hands.

## LAMP ADJUSTMENT

When this product left the factory, the lamp holder was calibrated here. However, due to the possibility of small deviations between lamps, fine adjustments after replacement may improve light output.

1. Turn on the lamp and operate with white beam (i.e. no effects)
2. Open the shutter and the iris with the dimmer intensity at 100%.
3. Focus the light beam on a flat surface (i.e. wall/floor)
4. Center the “ hot-spot ” (the brightest part of the image) using the 3 adjustment screws **X, Y & Z**.
5. Once the “ hot-spot ” has been centered, remove the “ hot-spot ” and balance the light output by turning the adjustment screws a quarter-turn clockwise one after another. If the “ hot-spot ” cannot be located, adjust the lamp until the light output is evenly distributed.
6. If the light output is brighter around the edge than in the center or if the light output is too low, the lamp is too far back from the reflector. Turn the screws **X, Y & Z** a quarter-turn anti-clockwise one after another until the light output is evenly distributed.

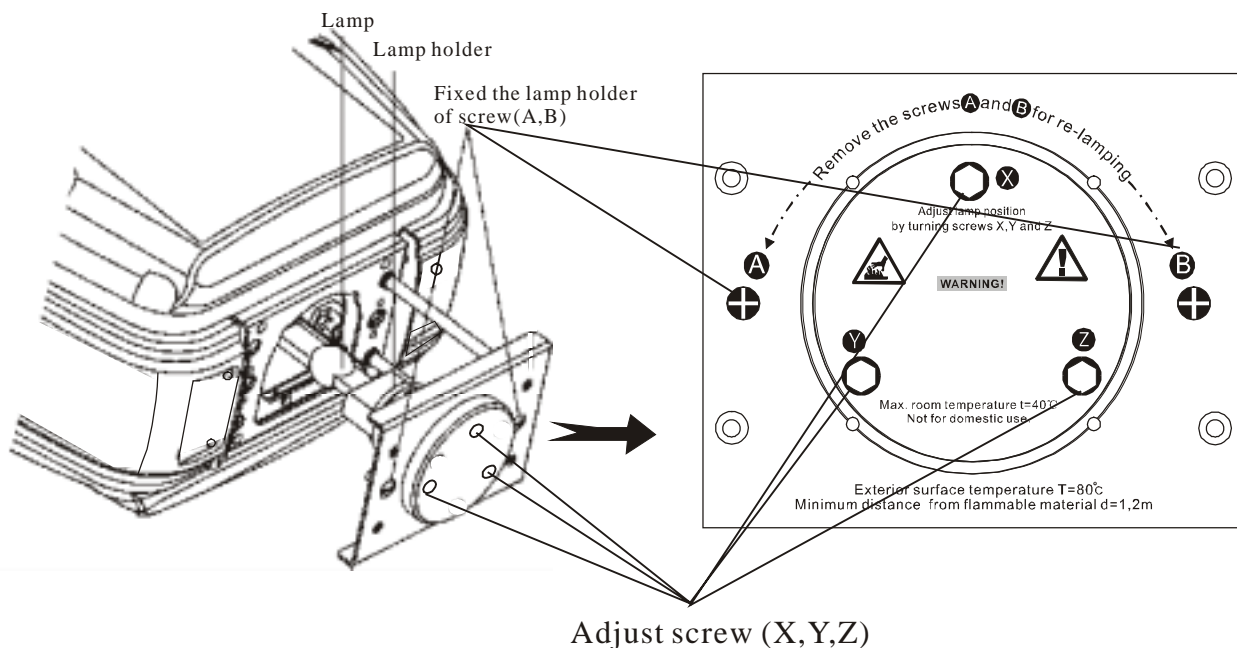

## INSERTING/EXCHANGING GOBOS, COLOURS AND EFFECTS

Turn off the lamp off , and at least 10 minutes allow the lamp to cool.  
Unplug from mains before!

### Rotating gobo wheel:

- 1) gently bend out the gobo holder to release it from the fixative holes and eject it from the pressing snap.
- 2) press the ends of the spring gobo-lock together with an appropriate tool and remove it.
- 3) Remove the distance ring and gobo and insert the new gobo (glazy side towards the lamp) with distance ring . Press the ends of the spring gobo-lock together and insert it in the front of the gobo.
- 4) put the gobo holder back under the pressing snap and push it to the 3 fixative notches.

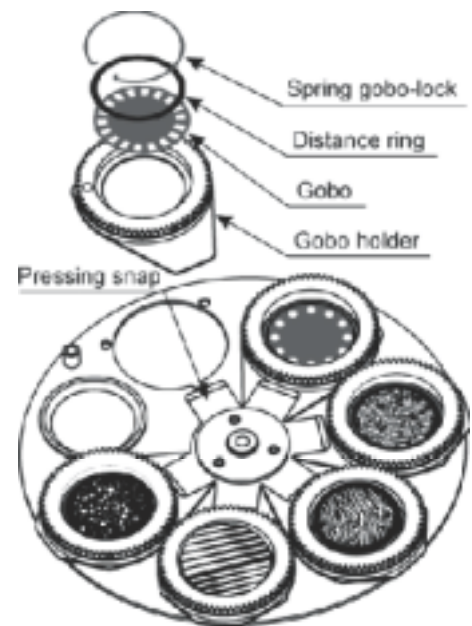

### Colour-wheel:

- 1) gently bend out the colour module to release it from the fixative holes and eject it from the pressing snap.
- 2) put the new colour module back under the pressing snap and push it to the 3 fixative notches.

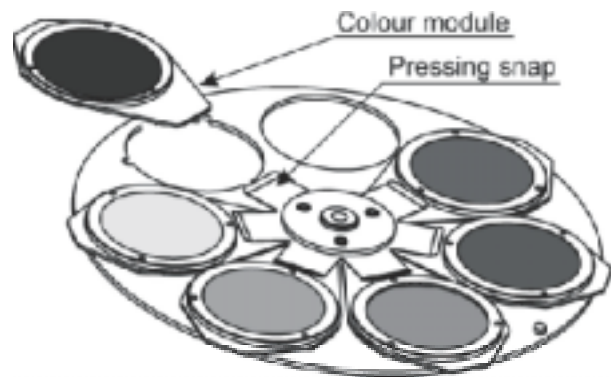

### Effect-wheel:

- 1) gently bend out the effect glass holder to release it from the fixative holes and eject it from the pressing snap.
- 2) press the ends of the spring glass-lock together with an appropriate tool and remove it. Remove the glass and insert the new one.
- 3) press the ends of the spring glass-lock together and insert it in the front of the glass.
- 4) put the glass effect holder back under the pressing snap and push it to the 3 fixative notches.

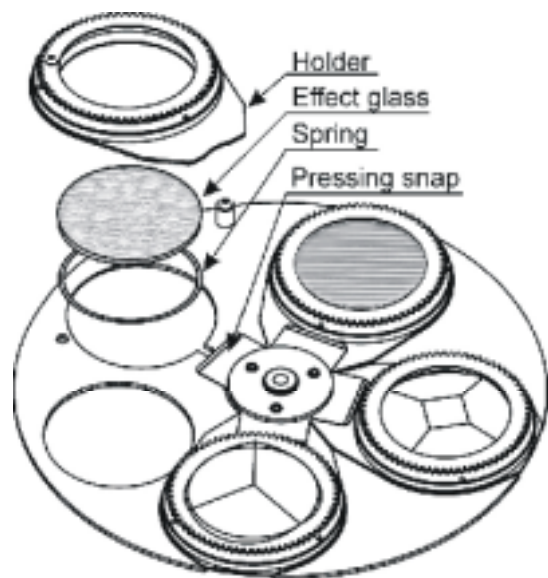

## RIGGING THE FIXTURE

**IMPORTANT: INSTALLATION MUST BE CARRIED OUT BY A QUALIFIED PROFESSIONAL.**

- The equipment must be mounted on equipment that has been designed and constructed in a way that can withstand 10 times the weight for 1 hour without any structural damage to the supporting structure.
- The installation must always be secured with a second safety attachment, e.g. safety cable. This secondary safety attachment must be connected in a way that allows no part of the equipment to fall to the ground if the main attachment fails.
- When rigging, derigging or servicing the fixture, all persons must clear the area below the work place.
- The user must have the safety and technical aspects of the installation checked by a qualified professional before commencing operation.
- The user must have the equipment checked every four years by a qualified expert or in accordance to local health and safety regulations.
- The user must have the installation checked by a qualified professional at least once a year.
- The equipment must be installed out of reach of people.
- The equipment must never be mounted swinging freely.
- This device can be placed directly on the stage floor or rigged in any orientation on a truss without altering its operating characteristics.

### **Mounting using the Omega-Holder:**

- 1) Bolt each clamp to the omega holder with a M12 bolt.
- 2) Attach the Omega-Holder to the bottom of the base by inserting both screw bolts into the base and tightening clockwise.
- 3) Connect the safety cable through the two holes in the bottom of the base and to the truss.

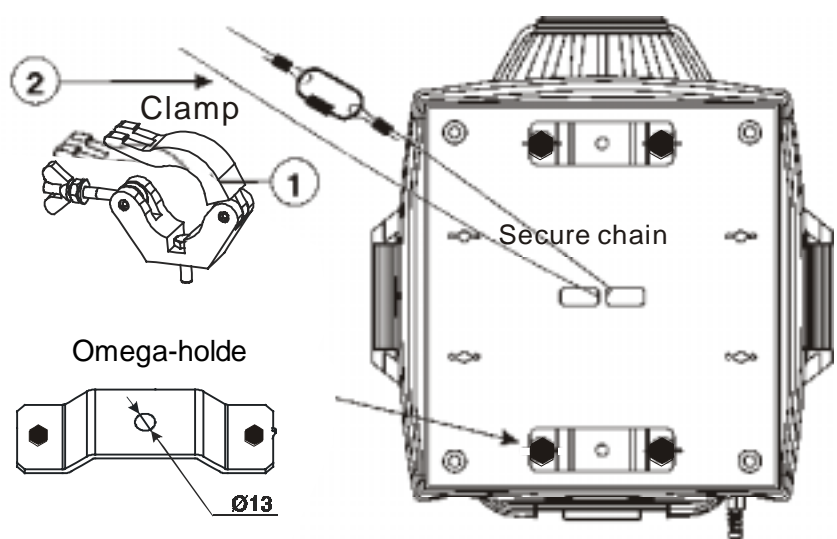

Possible omega holder 4 positions:

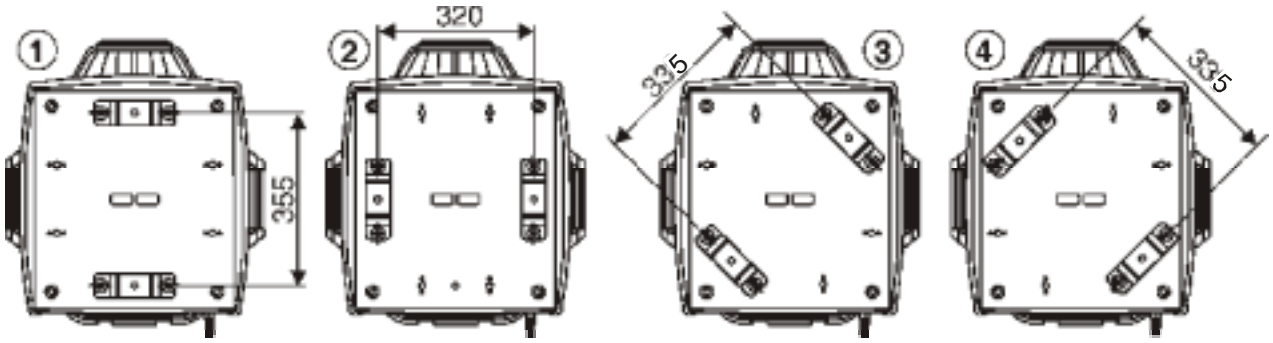

**DMX-512 connection/connection between fixtures**

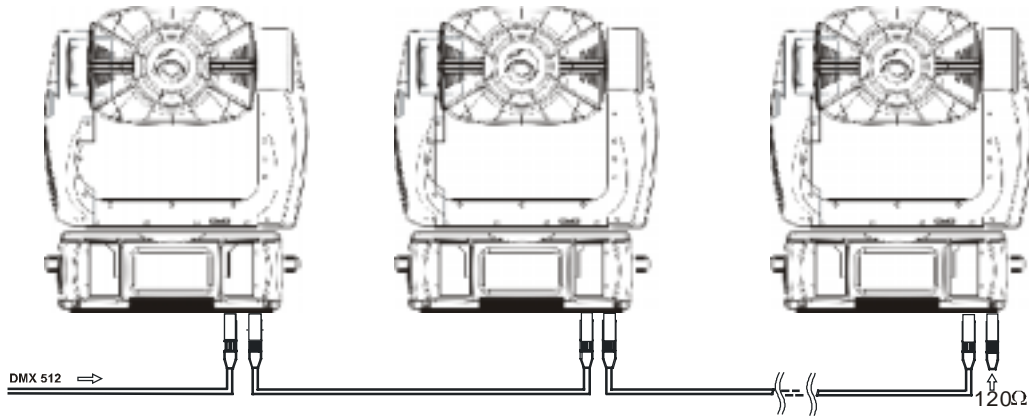

The fixture is equipped with both 3-pin and 5-pin XLR sockets for DMX input and output. The sockets are wired in parallel.

**Occupation of the XLR-connection:**

**DMX-OUTPUT  
XLR mounting-socket:**

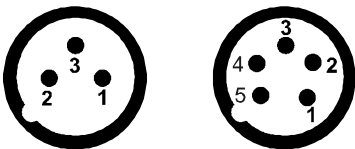

- 1- Ground
- 2 - Signal (-)
- 3 - Signal (+)
- 4 - Free
- 5 - Free

**DMX-input  
XLR mounting-plug:**

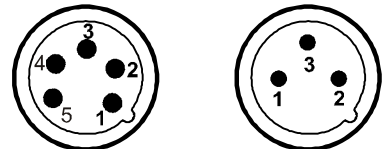

**Caution:** At the last fixture, the DMX-cable has to be terminated with a terminator. Solder a 120 Ω resistor between Signal (-) and Signal (+) into a 3-pin XLR-plug and plug it in the DMX-output of the last fixture.

**The transform of the controller line of 3 pins and 5 pins (plug and socket)**

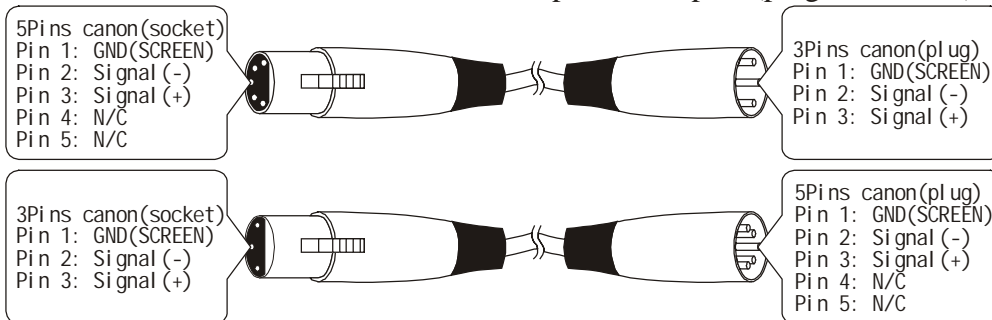

# CONTROL PANEL

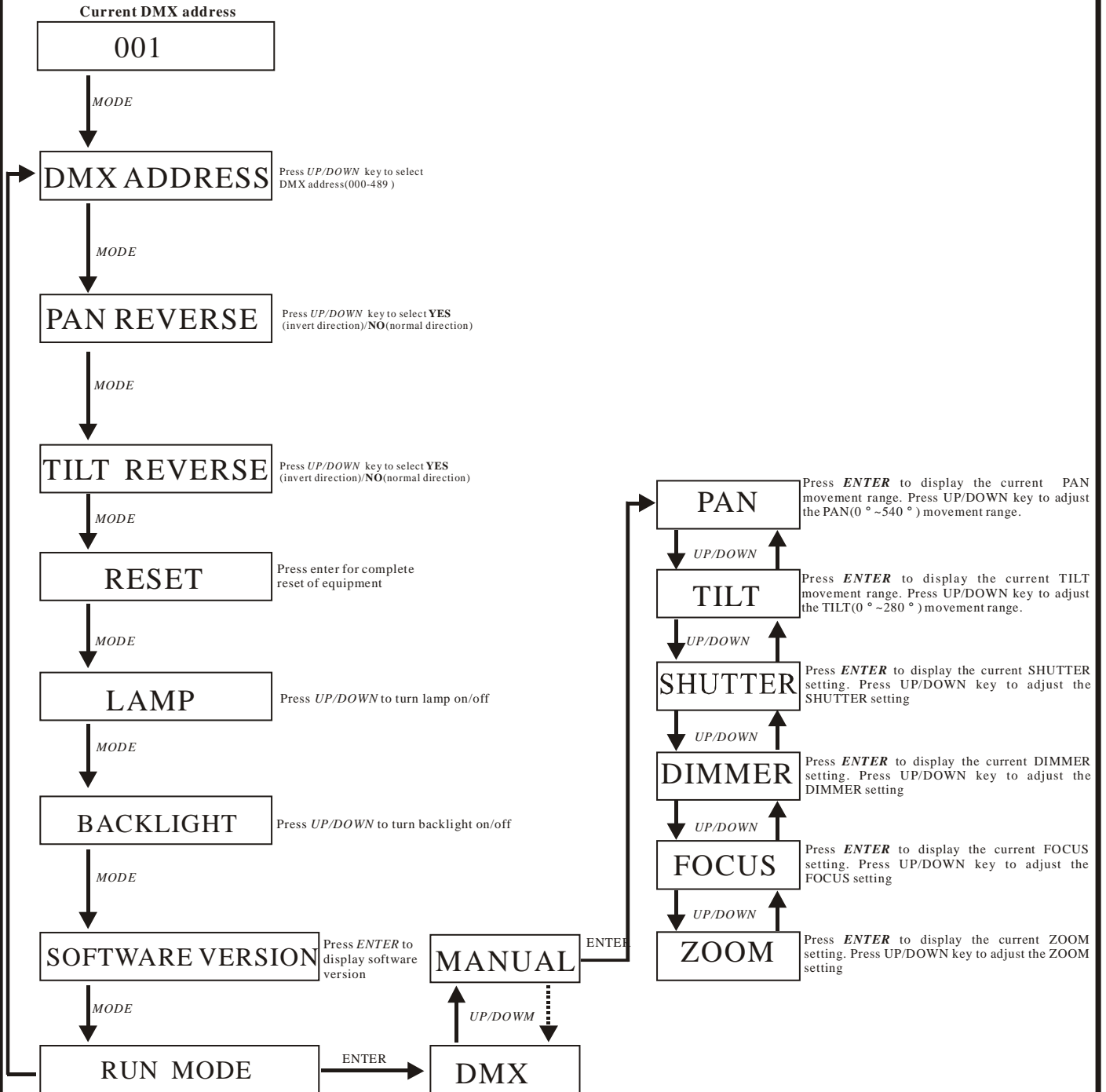

## DMX512 CHANNEL FUNCTION

CHANNEL	FUNCTION
1	Pan
2	Pan micro-step
3	Tilt
4	Tilt micro-step
5	Scan Speed
6	Lamp ON/OFF & reset
7	Colour
8	Cyan
9	Magenta
10	Yellow
11	3200k color temperature rectification(cto)
12	CYM +CTO speed adjust
13	Gobo wheel A
14	Gobo rotation (gobo wheel A)
15	Gobo wheel B
16	Gobo rotation(gobo wheel B)
17	Prism wheel
18	Prism rotation
19	Frost
20	Iris
21	Zoom
22	Focus
23	Strobe
24	Dimmer

### CHANNEL 1 : PAN

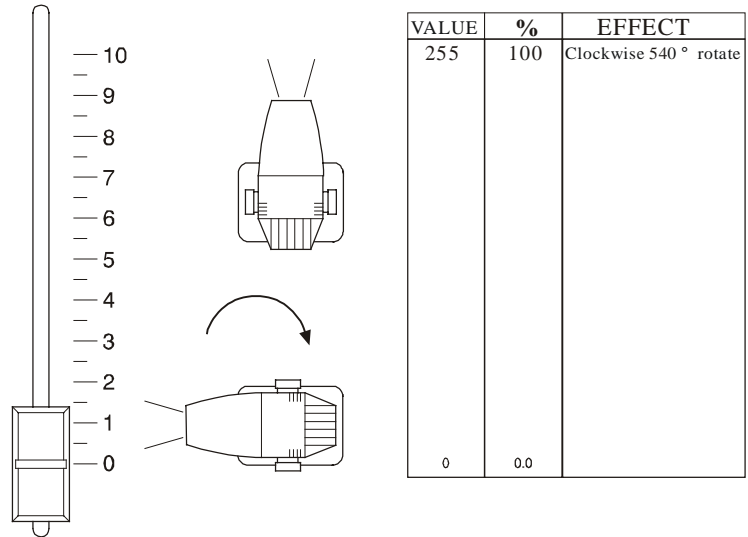

### CHANNEL 2: PAN FINE(proportional)

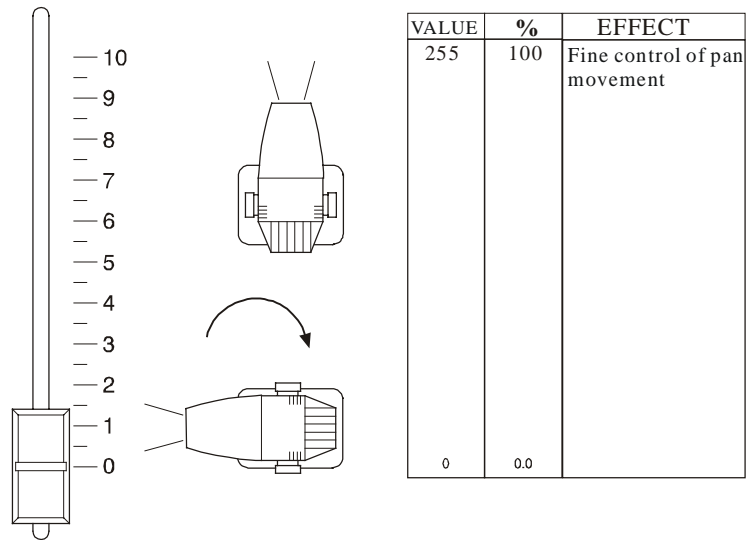

### CHANNEL 3 : TILT

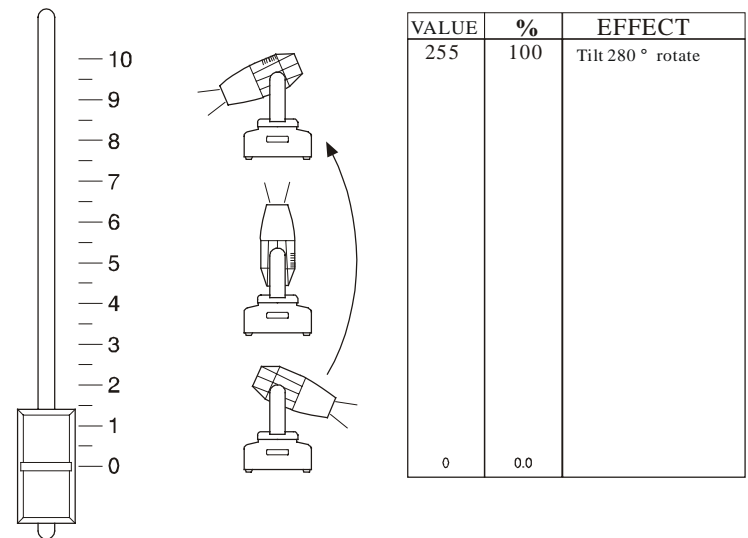

### CHANNEL 4: TILT FINE(proportional)

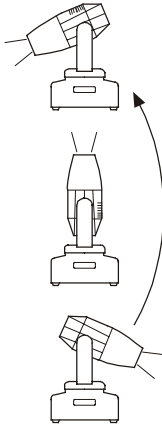
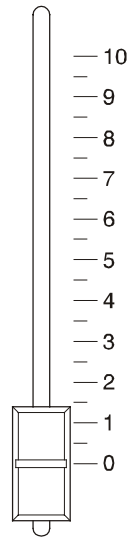

VALUE	%	EFFECT
255	100	Fine control of tilt movement
0	0.0	

### CHANNEL 5: SCAN SPEED ADJUST

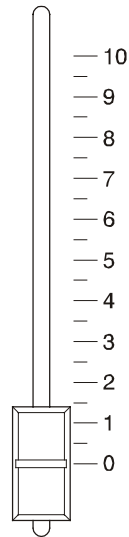

VALUE	%	EFFECT
255	100	Slow
0	0.0	Fast

### CHANNEL 6: LAMP ON/OFF & RESET

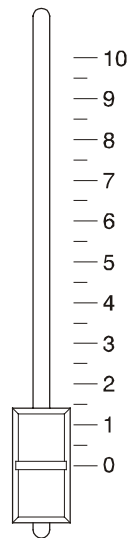

VALUE	%	EFFECT
240-255	94-100	No function
230-239	90-94	Lamp off after 3 seconds
140-229	55-90	No function
128-139	50-55	Lamp on after 3 seconds, Reset
0-127	0-50	No function

## CHANNEL 7: COLOR

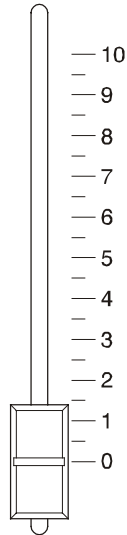

VALUE	%	EFFECT
197-255	77-100	Rainbow effect slow to fast
182	71	Uv filter
169	66	6000kcto
156	61	Green
143	56	Orange
130	51	Blue
117	46	Red
104	41	Open/hole
83-97	32-28	Uv filter
69-82	27-32	6000kcto
56-68	22-27	Green
42-55	16-22	Orange
28-41	11-16	Blue
14-27	5-11	Red
0-13	0-5	Open/hole

## CHANNEL 8: CYAN

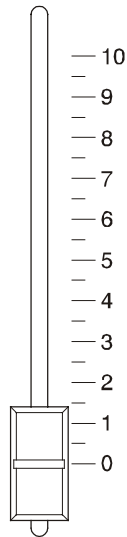

VALUE	%	EFFECT
255	100	Full cyan (gradually)
0	0.0	

## CHANNEL 9: MAGENTA

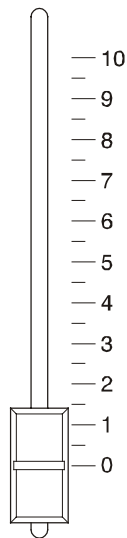

VALUE	%	EFFECT
	100	Full magenta (gradually)
	0.0	

### CHANNEL 10 : YELLOW

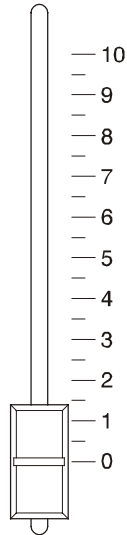

VALUE	%	EFFECT
255	100	Full yellow (gradually)
0	0	

### CHANNEL 11 : CONVERSION TEMPERATURE FILTER 3200K

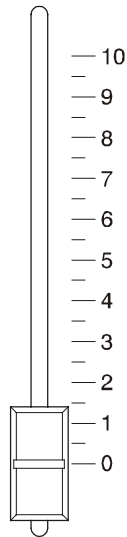

VALUE	%	EFFECT
255	100	0~100% 6000K~3200K
0	0	

### CHANNEL 12 : CMY+CTO CHANGE SPEED

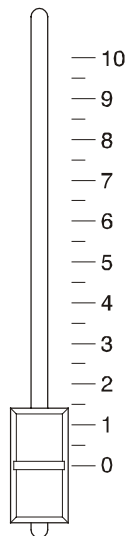

VALUE	%	EFFECT
255	100	Slow
0	0	Fast

## CHANNEL 13 : ROTATING GOBO WHEEL A

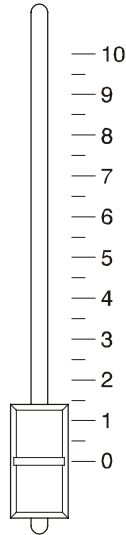

VALUE	%	EFFECT
220-255	86.5-100	Gobo flow effect
202-219	78.5-86.5	Shaking gobo 6
184-201	71.5-78.5	Shaking gobo5
166-183	65-71.5	Shaking gobo4
148-165	57.5-65	Shaking gobo3
130-147	50.5-57.5	Shaking gobo2
112-129	43.5-50.5	Shaking gobo 1
96-111	37-43.5	Gobo 6
80-95	31-37.5	Gobo5
64-79	25-31.5	Gobo4
48-63	18.5-25	Gobo3
32-47	18.5-25	Gobo2
15-31	12-18.5	Gobo 1
0-15	06-12	Open/hole

## CHANNEL 14 : GOBO ROTATION(GOBO WHEEL A)

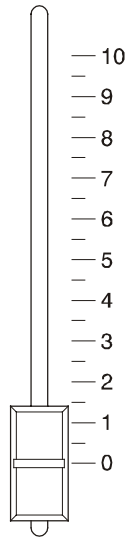

VALUE	%	EFFECT
159-255	62-100	Rotation gobo reverse rotate from slow to fast
61-158	24-62	Rotation gobo rotate from slow to fast
0-60	0-24	0-540 ° indexing

## CHANNEL 15 : ROTATING GOBO WHEEL B

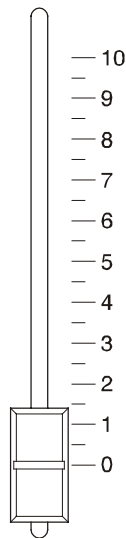

VALUE	%	EFFECT
220-255	86.5-100	Gobo flow effect
202-219	78.5-86.5	Shaking gobo 6
184-201	71.5-78.5	Shaking gobo5
166-183	65-71.5	Shaking gobo4
148-165	57.5-65	Shaking gobo3
130-147	50.5-57.5	Shaking gobo2
112-129	43.5-50.5	Shaking gobo 1
96-111	37-43.5	Gobo 6
80-95	31-37.5	Gobo5
64-79	25-31.5	Gobo4
48-63	18.5-25	Gobo3
32-47	18.5-25	Gobo2
15-31	12-18.5	Gobo 1
0-15	06-12	Open/hole

## CHANNEL 16 : GOBO ROTATION(GOBO WHEEL B)

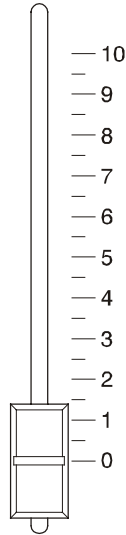

VALUE	%	EFFECT
159-255	62-100	Rotation gobo reverse rotate from slow to fast
61-158	24-62	Rotation gobo rotate from slow to fast
0-60	0-24	0-540 ° indexing

## CHANNEL 17 : PRISM EFFECT WHEEL

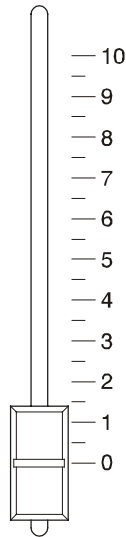

VALUE	%	EFFECT
211-255	83-100	5-facet prism
158-210	62-83	Stripe
105-157	41-62	3-facet prism
52-104	20-41	Diamante
0-51	0-20	Open/hole

## CHANNEL 18 : PRISM ROTATION

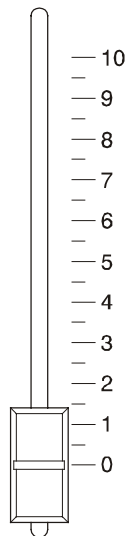

VALUE	%	EFFECT
133-255	52-100	Backwards effect rotation from fast to slow
128-132	50-52	No rotation
5-127	2-50	Forwards effect rotation from fast to slow
0-4	0-2	No rotation

## CHANNEL 19 : FROST

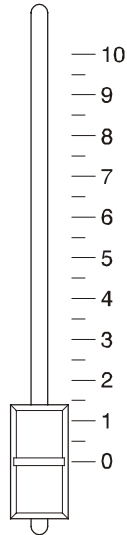

VALUE	%	EFFECT
234-255	92-100	No function
212-233	83-92	pulse opening
190-211	74-83	pulse closing
180-189	70-74	100%forst
0-179	0-70	open

## CHANNEL 20 : IRIS

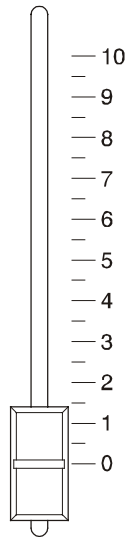

VALUE	%	EFFECT
234-255	92-100	No function
212-233	83-92	From max. to min. diameter closed
190-211	74-83	From min. to max. diameter opened
180-189	70-74	Min.diameter
0-179	0-70	Plug closing from max to min

## CHANNEL 21 : ZOOM

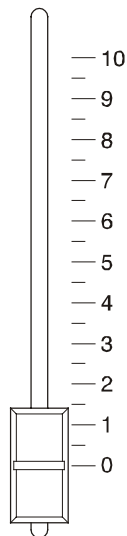

VALUE	%	EFFECT
255	100	Min zoom
0	0	Max zoom

## CHANNEL 22 : FOCUS

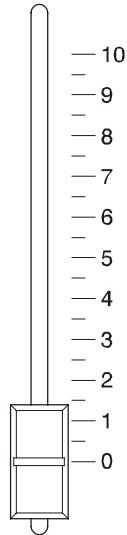

VALUE	%	EFFECT
255	100	From far to near focus
0	0	

## CHANNEL 23 : STROBE

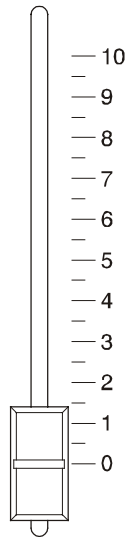

VALUE	%	EFFECT
224-255	88-100	Open/hole
192-223	75-88	Random strobe-effect from slow to fast
160-191	63-75	Open/hole
128-159	50-63	Pulse-effect in sequences from slow to fast
96-127	38-50	Open/hole
64-95	25-38	Strobe from slow to fast
32-63	12-25	Open/hole
0-31	0-12	Shutter

## CHANNEL 24 : DIMMER

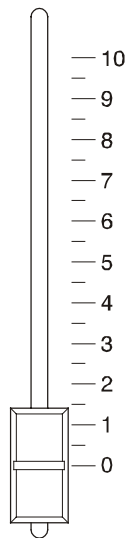

VALUE	%	EFFECT
255	100	Dimmer intensity form 0% to 100%
0	0	

---

## 8. Technical specifications

**US-model:** Voltage.....AC100/110/120V , 50/60Hz  
Fuse..... T 20 A@120V  
**EU-model:** Voltage.....AC220/230/240V ,50/60Hz  
Fuse .....T10A @230V

**Rated Power : 1600W**

**DMX512 Channel : 24CHS**

**Luminous : 96000 LM**

**Lamp:**

- MSR1200 SA GY 22
- Colour temperature 6000K
- Average lifespan:750hrs

**Optical System:**

- Focus: electronic linear focus
- Zoom: electronic zoom 13 ° ~42 °
- Dimmer: smooth dimmer 0~100%
- Strobe: Variable speed 1~10 flashes/sec (plus random strobe effect)
- Frost filter: smooth adjust 0~100%
- Iris: Electronic linear iris

**Rotating gobo**

- 12 gobos (interchangeable)
- Gobo-flow effect
- Bi-directional rotation & 0 ° ~540 ° indexing

**Colour wheel:**

- 6 dichroic-filters, UV, CTF 6000K plus white step/linear rotation(plus bi-directional rainbow -flow effect)

**Rigging:**

- Stands directly on the floor
- Mounts horizontally or vertically with 2 clamps
- 2 truss orientation
- Safety chain/cord attachment bolt

**Pan / Tilt Movement:**

- Pan 530 ° , Tilt 280 °
- Micro-step scan effect
- Auto-repositioning by photoelectric repositioning system
- Linearity move speed adjust.

**Prisms:** 3-facet prism / 5-facet prism(dual direction rotation with adjustable speed)

**Dimensions and weight:**

- Length of base (including handles): 506 mm
- Width of yoke: 525 mm
- Height (head horizontal): 602 mm
- Weight (net): 60 kg

# Beampath:

波束路径: Beam angle 13° - min. Zoom

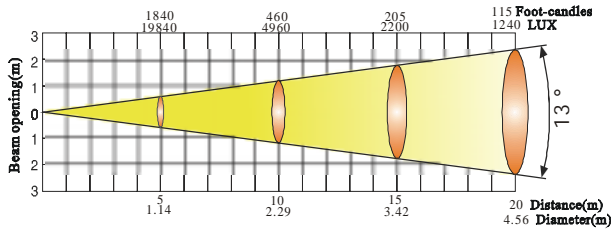

Beam angle 42° - max. zoom

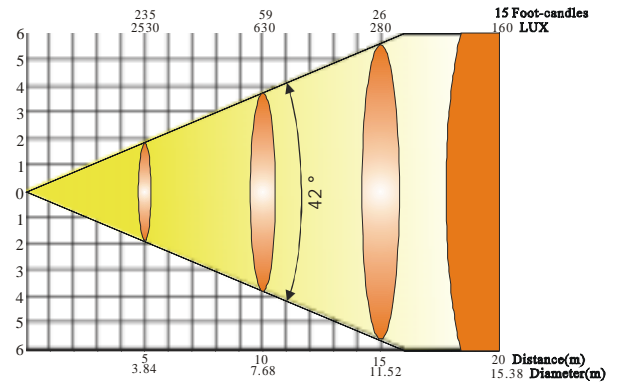

Beam angle 13° with frost

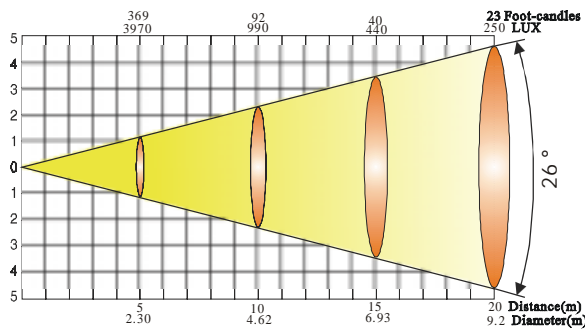

Beam angle 42° with frost

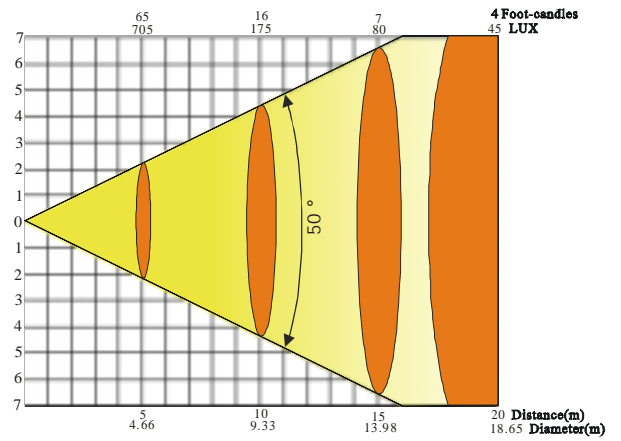

Beam angle 13° with frost, distance=5m

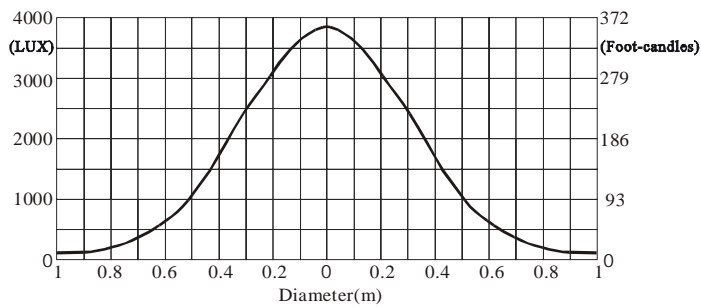

Beam angle 42° with frost, distance=5m

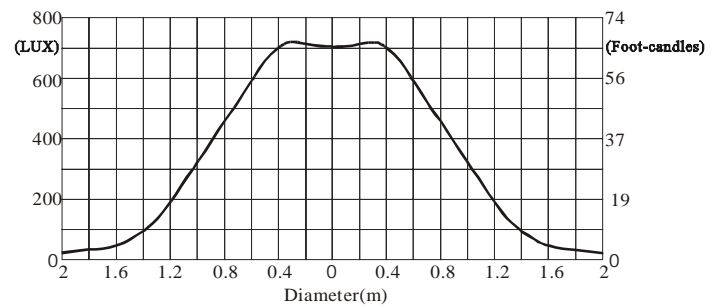

---

## Maintenance and cleaning

It is absolutely essential that the fixture is kept clean and that dust, dirt and smoke-fluid residues must not buildup on or within the fixture. Otherwise, the fixtures light-output will be significantly reduced. Regular cleaning will not only ensure the maximum light-output, but will also allow the fixture to function reliably throughout its life. A soft lint-free cloth moistened with any good glass cleaning fluid is recommended, under no circumstances should alcohol or solvents be used!

### **DANGER : Disconnect from the mains before starting any maintenance work**

The front objective lens will require weekly cleaning as smoke-fluid tends to building up residues, reducing the light-output very quickly. The cooling-fans should be cleaned monthly.

The gobos may be cleaned with a soft brush. The interior of the fixture should be cleaned at least annually using a vacuum-cleaner or an air-jet.

The dichroic colour-filters, the gobo-wheel and the internal lenses should be cleaned monthly.

To ensure a proper function of the gobo-wheel, we recommend lubrication in six month intervals. The quantity of oil must not be excessive in order to avoid that oil runs out when the gobo-wheel rotates.

There are no serviceable parts inside the device except for the lamp and the fuse. Please refer to the instructions under "Fitting/Exchanging the lamp". Maintenance and service operations are only to be carried out by authorized dealers.

### **Replacing the fuse**

If the lamp burns out, the fine-wire fuse of the device might fuse, too. Only replace the fuse by a fuse of same type and rating. Before replacing the fuse, unplug mains lead.

#### **Procedure:**

- 1) Unscrew the fuseholder on the rear panel of the base with a fitting screwdriver from the housing (anti- clockwise).
- 2) Remove the old fuse from the fuseholder.
- 3) Install the new fuse in the fuseholder.
- 4) Replace the fuseholder in the housing and fix it.